



# SN-SPCP-FDR2

SECURITY. SHOCK DETECTOR FOR DOORS/WINDOWS



RATE US!

P/N SN-SPCP-FDR2

## DESCRIPTION

Stand-alone detector with **DSF (DEA Sensor Fusion)** technology for the protection of **doors and windows** against **light impacts, strong impacts, breakthrough** events and **continuous vibrations**. It couples the robustness and reliability of the piezoelectric transducer, the accuracy of the MEMS technology with an integrated electronics which ensures Point identification and calibration of the sensor. It is equipped with an anti-removal device and calibration is eased by means of dip-switches.

## PACKAGE CONTENTS

- In addition to the datasheet herein, the pack contains:
- 1 no SN-SPCP-FDR2M detector
  - 2 no round head self-tapping screws 3x16 mm (for fixing the sensor to the structure)
  - 2 no round head self-tapping screws 3x16 mm (for fixing the sensor with base)
  - 1 no mini screwdriver

## COVERAGE AREA

SN-SPC-FDR2M detector protects the whole structure, including glazed surface (if any), up to 4 sqm (see Application example). However, such value can decrease depending on the conditions and the features of the window/door.

## INSTALLATION

To open the detector, put off the light guide present on the cover (1), raise it from its right side (opposite to DEA Security brand); insert the screwdriver in the side hole (2) and prising the unlocking support. Make the cable (3) pass through the desired hole (on the base or on the sensor side) and fix to the structure (4) with the supplied screws.

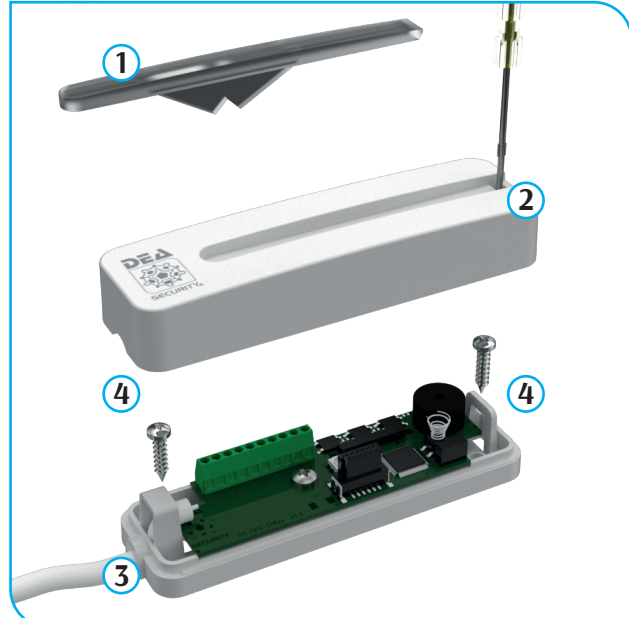

## COMPLIANCE

- DIRECTIVE 2014/30/EU**
  - EN 50130-4:2011
  - EN 61000-6-3:2007+A1:2011
- DIRECTIVE 2011/65/EU**
  - EN 50581:2012
- STANDARD EN-50131-1/A2:2017**
  - EN-50131-2-8:2016



## TECHNICAL FEATURES

- SECURITY GRADING:** Grade 3 certified (EN 50131-2-8)
- ENVIRONMENTAL CLASS:** Class II certified
- DIMENSIONS:** sensor 89 x 26 x 20 mm (L x H x D)
- PACKAGING DIMENSIONS:** 110 x 75 x 35 mm (L x H x D)
- GROSS WEIGHT:** 62 g
- NET WEIGHT:** 46 g
- CASE MATERIAL:** ABS
- COLOUR:** white
- POWER SUPPLY:** 12 V<sub>cc</sub> ±25% (nominal)  
8 V (low supply voltage)  
20 mA
- CURRENT:** 20 mA
- OPERATING TEMPERATURE:** -20 °C ÷ +70 °C
- RELATIVE HUMIDITY:** <95% non condensing
- IP RATING:** IP40
- FUNCTIONS AND DEVICES:** anti-removal and anti-opening tamper  
Reset and ARM (for alarm memory)
- INPUTS:**
- OUTPUTS (NC):** alarm line (continuous impacts, low attacks, gross attacks and heavy attacks), power fail tamper line
- AVERAGE COVERAGE AREA:** 4 m<sup>2</sup>

## DIMENSIONAL SCHEME

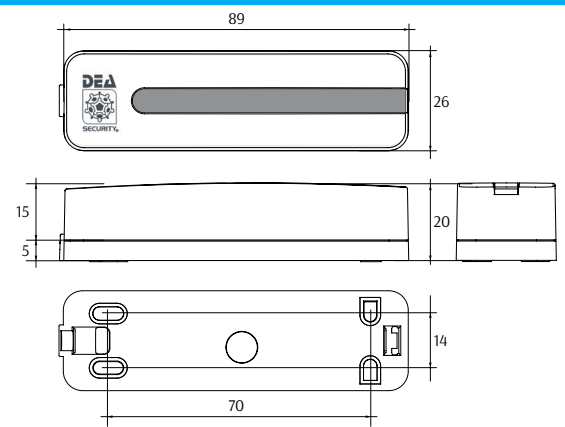

## APPLICATION EXAMPLE





## CONNECTIONS

The detector is equipped with a 10-way terminal block: 12 V<sub>DC</sub> power supply (+ e -), RESET input (1), ARM alarm memory (2), alarm output (ALARM), power fail signal, tamper output (TAMP).

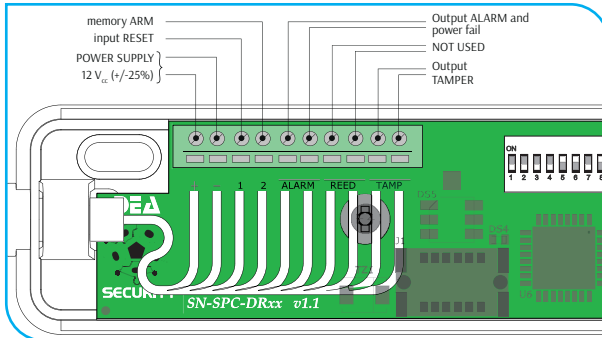

**AFTER POWERED THE SENSOR, WAIT FOR THE INITIALIZATION FUNCTIONAL CHECKS. AT THIS STAGE THE SENSOR MUST BE FIXED. ONCE INITIALIZATION IS COMPLETE, THE LED SIGNALS CORRECT OPERATION (BLUE FLASHES) OR MALFUNCTIONS (MAGENTA FLASHES).**



## CALIBRATION

Calibration and configuration are performed via dip-switches.

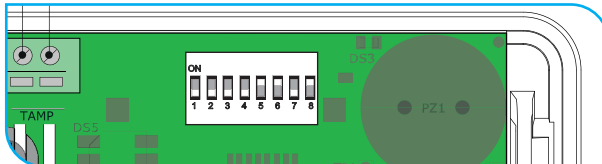

### ■ CALIBRATION ACCORDING TO EN 50131-2-8

In accordance with standard EN 50131-2-8, the detector calibration must be the following, depending on the protected structures:

	DIP SWICHTH								
<b>WINDOW - default</b> (Generic window with glass)	ON	1	2	3	4	5	6	7	8
	OFF	●	●	●	●	●	●	●	●
<b>WOOD</b> (wooden plate)	ON	1	2	3	4	5	6	7	8
	OFF	●	●	●	●	●	●	●	●
<b>CONCRETE</b> (concrete plate)	ON	1	2	3	4	5	6	7	8
	OFF	●	●	●	●	●	●	●	●



**FOR THE SELECTION OF THE PRESETS COMPLIANT TO STANDARD EN 50131-2-8, YOU NEED TO OPERATE DIP-SWITCHES 1,2,3 ONLY. IN THIS CONFIGURATION THE REMAINING DIP-SWITCHES DO NOT MODIFY ANOTHER PARAMETERS.**

### ■ DIP-SWITCH FUNCTIONS AND CUSTOM CALIBRATION

DIP SWICHTH	FUNZIONE
1 - 2 - 3	Sensitivity and programming levels
4 - 5	Low attack counting
6	Enable (ON) or disable (OFF) continuous vibrations
7	Memory time for low attack counting (OFF = 45" - ON = 1'30")
8	Enable (ON) or disable (OFF) led.

The detector can be custom calibrated via dip-switches, as shown below:

- sensitivity and programming levels

Levels	DIP SWICHTHES																								
<b>1 (MINIMUM)</b>	<table border="1"> <tr><td>1</td><td>2</td><td>3</td><td>4</td><td>5</td><td>6</td><td>7</td><td>8</td></tr> <tr><td>ON</td><td>●</td><td>●</td><td>●</td><td>●</td><td>●</td><td>●</td><td>●</td></tr> <tr><td>OFF</td><td>●</td><td>●</td><td>●</td><td>●</td><td>●</td><td>●</td><td>●</td></tr> </table>	1	2	3	4	5	6	7	8	ON	●	●	●	●	●	●	●	OFF	●	●	●	●	●	●	●
1	2	3	4	5	6	7	8																		
ON	●	●	●	●	●	●	●																		
OFF	●	●	●	●	●	●	●																		
<b>2</b>	<table border="1"> <tr><td>1</td><td>2</td><td>3</td><td>4</td><td>5</td><td>6</td><td>7</td><td>8</td></tr> <tr><td>ON</td><td>●</td><td>●</td><td>●</td><td>●</td><td>●</td><td>●</td><td>●</td></tr> <tr><td>OFF</td><td>●</td><td>●</td><td>●</td><td>●</td><td>●</td><td>●</td><td>●</td></tr> </table>	1	2	3	4	5	6	7	8	ON	●	●	●	●	●	●	●	OFF	●	●	●	●	●	●	●
1	2	3	4	5	6	7	8																		
ON	●	●	●	●	●	●	●																		
OFF	●	●	●	●	●	●	●																		
<b>3</b>	<table border="1"> <tr><td>1</td><td>2</td><td>3</td><td>4</td><td>5</td><td>6</td><td>7</td><td>8</td></tr> <tr><td>ON</td><td>●</td><td>●</td><td>●</td><td>●</td><td>●</td><td>●</td><td>●</td></tr> <tr><td>OFF</td><td>●</td><td>●</td><td>●</td><td>●</td><td>●</td><td>●</td><td>●</td></tr> </table>	1	2	3	4	5	6	7	8	ON	●	●	●	●	●	●	●	OFF	●	●	●	●	●	●	●
1	2	3	4	5	6	7	8																		
ON	●	●	●	●	●	●	●																		
OFF	●	●	●	●	●	●	●																		
<b>4</b>	<table border="1"> <tr><td>1</td><td>2</td><td>3</td><td>4</td><td>5</td><td>6</td><td>7</td><td>8</td></tr> <tr><td>ON</td><td>●</td><td>●</td><td>●</td><td>●</td><td>●</td><td>●</td><td>●</td></tr> <tr><td>OFF</td><td>●</td><td>●</td><td>●</td><td>●</td><td>●</td><td>●</td><td>●</td></tr> </table>	1	2	3	4	5	6	7	8	ON	●	●	●	●	●	●	●	OFF	●	●	●	●	●	●	●
1	2	3	4	5	6	7	8																		
ON	●	●	●	●	●	●	●																		
OFF	●	●	●	●	●	●	●																		
<b>5 (MAXIMUM)</b>	<table border="1"> <tr><td>1</td><td>2</td><td>3</td><td>4</td><td>5</td><td>6</td><td>7</td><td>8</td></tr> <tr><td>ON</td><td>●</td><td>●</td><td>●</td><td>●</td><td>●</td><td>●</td><td>●</td></tr> <tr><td>OFF</td><td>●</td><td>●</td><td>●</td><td>●</td><td>●</td><td>●</td><td>●</td></tr> </table>	1	2	3	4	5	6	7	8	ON	●	●	●	●	●	●	●	OFF	●	●	●	●	●	●	●
1	2	3	4	5	6	7	8																		
ON	●	●	●	●	●	●	●																		
OFF	●	●	●	●	●	●	●																		

## N.B.

**THE SENSITIVITY CAN BE INCREASED CONSIDERING LEVEL 1 AS MINIMUM SENSITIVITY AND LEVEL 2 AS MAXIMUM SENSITIVITY.**

- event number counting (low attacks)

Event No counting	DIP SWICHTHES	Event No counting	DIP SWICHTHES																																																
<b>2</b>	<table border="1"> <tr><td>1</td><td>2</td><td>3</td><td>4</td><td>5</td><td>6</td><td>7</td><td>8</td></tr> <tr><td>ON</td><td>●</td><td>●</td><td>●</td><td>●</td><td>●</td><td>●</td><td>●</td></tr> <tr><td>OFF</td><td>●</td><td>●</td><td>●</td><td>●</td><td>●</td><td>●</td><td>●</td></tr> </table>	1	2	3	4	5	6	7	8	ON	●	●	●	●	●	●	●	OFF	●	●	●	●	●	●	●	<b>4</b>	<table border="1"> <tr><td>1</td><td>2</td><td>3</td><td>4</td><td>5</td><td>6</td><td>7</td><td>8</td></tr> <tr><td>ON</td><td>●</td><td>●</td><td>●</td><td>●</td><td>●</td><td>●</td><td>●</td></tr> <tr><td>OFF</td><td>●</td><td>●</td><td>●</td><td>●</td><td>●</td><td>●</td><td>●</td></tr> </table>	1	2	3	4	5	6	7	8	ON	●	●	●	●	●	●	●	OFF	●	●	●	●	●	●	●
1	2	3	4	5	6	7	8																																												
ON	●	●	●	●	●	●	●																																												
OFF	●	●	●	●	●	●	●																																												
1	2	3	4	5	6	7	8																																												
ON	●	●	●	●	●	●	●																																												
OFF	●	●	●	●	●	●	●																																												
<b>3</b>	<table border="1"> <tr><td>1</td><td>2</td><td>3</td><td>4</td><td>5</td><td>6</td><td>7</td><td>8</td></tr> <tr><td>ON</td><td>●</td><td>●</td><td>●</td><td>●</td><td>●</td><td>●</td><td>●</td></tr> <tr><td>OFF</td><td>●</td><td>●</td><td>●</td><td>●</td><td>●</td><td>●</td><td>●</td></tr> </table>	1	2	3	4	5	6	7	8	ON	●	●	●	●	●	●	●	OFF	●	●	●	●	●	●	●	<b>5</b>	<table border="1"> <tr><td>1</td><td>2</td><td>3</td><td>4</td><td>5</td><td>6</td><td>7</td><td>8</td></tr> <tr><td>ON</td><td>●</td><td>●</td><td>●</td><td>●</td><td>●</td><td>●</td><td>●</td></tr> <tr><td>OFF</td><td>●</td><td>●</td><td>●</td><td>●</td><td>●</td><td>●</td><td>●</td></tr> </table>	1	2	3	4	5	6	7	8	ON	●	●	●	●	●	●	●	OFF	●	●	●	●	●	●	●
1	2	3	4	5	6	7	8																																												
ON	●	●	●	●	●	●	●																																												
OFF	●	●	●	●	●	●	●																																												
1	2	3	4	5	6	7	8																																												
ON	●	●	●	●	●	●	●																																												
OFF	●	●	●	●	●	●	●																																												

## N.B.

**THE DETECTION OF THE CONTINUOUS VIBRATIONS (ATTACKS PERFORMED WITH ELECTRIC TOOLS, SUCH AS CIRCULAR SAWS) DOES NOT NEED ANY CALIBRATION.**

## DEA Security S.r.l.

Via Bolano, snc - 19037 Santo Stefano di Magra (SP) - tel. +39 0187 699233 - fax +39 0187 697615  
 VAT NO.: IT00291080455  
 www.deasecurity.com - dea@deasecurity.com

© 2023 DEA Security S.r.l. - Edition December 2022 - v. 1.0.6.

DEA Security srl reserve the right to change at any time and without notice the features of its products.



SCAN ME